

# TXgard-Plus

## Flameproof

### Toxic and Oxygen

#### Gas Detector

##### With Non-Intrusive One-man

##### Calibration

# Plus

**1.1 Product overview**

TXgard-Plus is a flameproof toxic and oxygen gas detector suitable for use in zone 1 or 2 hazardous areas. It is designed without a hot work permit. Powered by 24 V dc (nominally) TXgard-Plus provides a 4-20 mA signal (sink or source) proportional to the gas concentration and can also be fitted with optional alarm and fault relays. For a list of gases that can be detected, please contact Crowcon.

**1.2 Product description**

TXgard-Plus comprises four parts: 96HD sensor housing, junction box, amplifier and terminal board. Diagram 1 details TXgard-Plus. The overall assembly is certified EX d IIC T6 in Europe and Class 1, Zones 1&2 AEx d IIC T6 in the USA. The 96HD sensor housing is a modular stainless steel assembly that disassembles to allow plug in sensors to be replaced easily (see Diagram 4). The assembly screws into an M20 entry on the junction box.

The junction box is manufactured from marine grade alloy and is supplied with 2 x M20 (1/2" NPT for USA) cable entries for customer use. Alternative cable entries are available from Crowcon.

The amplifier plugs into the terminal board, and is held in place by two captive screws. The amplifier provides power to the sensor, local display and controls, and a 4-20 mA signal proportional to the gas concentration for connection to a control panel. To remove, turn screws anti-clockwise and pull amplifier out of the enclosure.

All electrical connections are made via the terminal board mounted in the base of the junction box (see Diagram 2). Optional alarm relays (AL1 & AL2) and one fault relay (FAULT) are mounted on the terminal board which may be used to drive local warning devices or connect TXgard-Plus to a control panel.

**1.1 Product overview**

**1.3 Status indication**

TXgard-Plus includes a local display and status LED, visible through the junction box window, see Diagram 1. The display shows the gas concentration and current mode of operation i.e. NORMAL, ZERO or CAL. The LED shows the current alarm state of the detector. This is summarised in Table 1.

Operational state	LED indication	Relay States	Comment
Normal operation	Steady green	AL1 - Off AL2 - Off	Gas level < AL1 Current output = 4-20 mA
Normal operation	Steady red	AL1 - On AL2 - On	Gas level > AL1 < AL2 Current output = 4-20 mA
Normal operation	Fashing red	AL1 - On AL2 - On	Current output = 4-20 mA
Over-range	Fashing red	AL1 - On AL2 - On	Gas level > full scale Display backlight flashes
Zero/calibration mode	Fashing green	AL1 - On AL2 - On	Configuration dependent Latched until reset via 'MENU' Current output = 2 mA
Detector	Steady amber	AL1 - Off AL2 - Off	Current output = 0 mA (see section 2) (4 mA option)
Fault	Steady red	FAULT - Off	FAULT - Off

\*See section 2 for AL1 and AL2 standard settings

Table 1: LED status indicator summary.

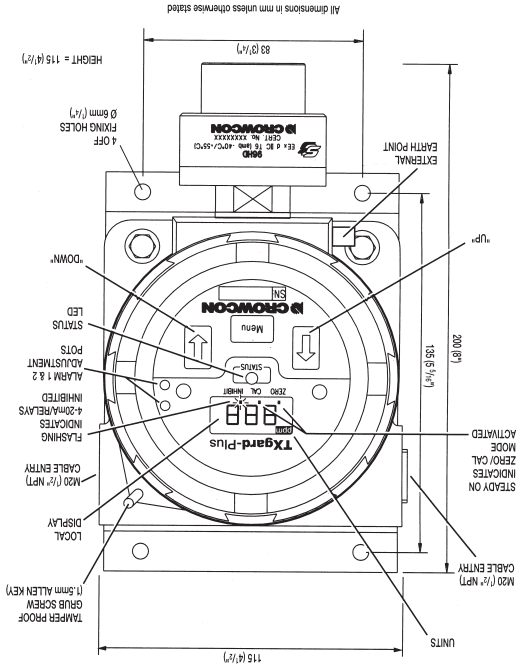

Diagram 1: TXgard Plus general arrangement

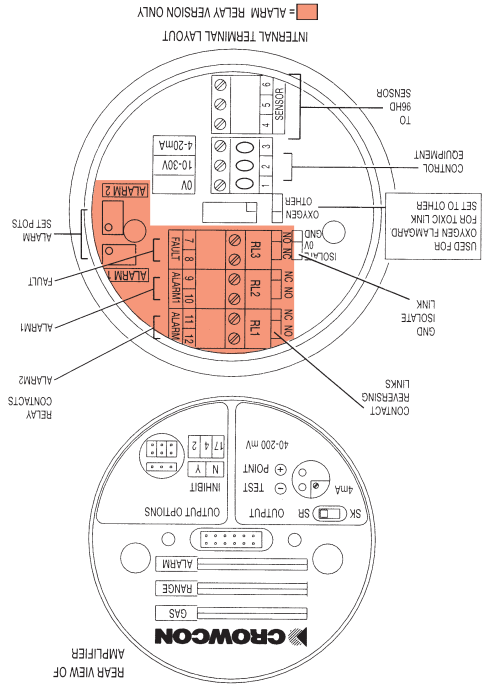

Diagram 2: Terminal and amplifier layouts

## 2. DETECTOR CONFIGURATION

**2.1 Standard configuration**

As standard, TXgard-Plus is factory set as follows:

Current source with	AL1 relay (if fitted)	AL2 relay (if fitted)	FAULT relay (if fitted)	INHIBIT
0 mA = Fault 2 mA = Inhibit i.e. Zero/CAL mode 4-20 mA = Normal operation 24 mA = Over-range clamp	• Alarm level 1, see Table 3 • Normally de-energised, energising on alarm • Contact normally open (NO), closing on alarm	• Alarm level 2, see Table 3 • Normally de-energised, energising on alarm • Contact normally open (NO), closing on alarm	• Normally energised, de-energised on fault • Contact normally closed (NC), opening on fault	• Normally selected, ie. when CAL/ZERO selected current output is forced to 2mA and relays are held in normal/no alarm state.

Table 2: Standard configuration for TXgard-Plus.

**2.4 Inhibit options**

To not inhibit 4-20 mA signal and relays, fit link to 'N' and link to '4'.

**2.3 Relay options**

To change AL1 or AL2 relay from NO to NC, fit link in the 'NC' position. To change FAULT relay from NC to NO, fit link in the 'NO' position.

**2.2 4-20mA options**

To change current source output to sink, set switch to 'SK' position. To change inhibit from 2 mA to 4 mA, fit link to '4' position.

\*Alternative ranges and alarm set points must be specified when ordering

Gas	Range*	AL1*	AL2*
Hydrogen sulphide	0-25 ppm	5 ppm	10 ppm
Carbon monoxide	0-250 ppm	30 ppm	200 ppm
Oxygen	0-25% v/v	19% v/v	17% v/v

Table 3 details standard alarm points for the available gases and ranges.

Table 3: Standard ranges and alarm set points.

Location of links are shown in Diagram 2.

To detect gases which are lighter than air, detectors should be mounted at high level and Crowcon recommend the use of a collector cone (Part No. C01051).

**2.3 Relay options**

To detect heavier than air gases (eg hydrogen sulphide), detectors should be mounted at low level.

**2.4 Inhibit options**

Consider ease of access for functional testing and servicing. Recommend the use of a Weatherproof Cap (Part No. C01442).

When locating detectors consider the possible damage caused by natural events e.g. rain or flooding. For detectors mounted outdoors Crowcon recommend the use of a Weatherproof Cap (Part No. C01442).

Consider how the escaping gas may behave due to natural or forced air currents. Mount detectors in ventilation ducts if appropriate.

**3.1 Location**

There are no rules which dictate the siting and location of detectors, however, considerable guidance is available from BS EN 50073:1999 and British Standard Code of Practice for the Selection, Use and Maintenance of Apparatus for the Detection and Measurement of Combustible Gases or Oxygen. In the USA refer to the National Electrical Code (NEC 1999). Similar international codes of practice may be used where applicable. In addition certain regulatory bodies publish specifications giving minimum gas detection requirements for specific applications.

**3.2 Mounting**

The mounting detail of TXgard-Plus is given in Diagram 1. TXgard-Plus should be installed at the designated location with the detector pointing down. This ensures that dust or water will not collect on the sinter and stop gas entering the detector.

**3.3 Cabling requirement**

Cabling to TXgard-Plus must be in accordance with the recognised standards of the appropriate authority in the country concerned and meet the electrical requirements of the detector. Crowcon recommend the use of steel wire armoured (SWA) cable and suitable explosion proof glands must be used. Alternative cabling techniques, such as steel conduit, may be acceptable provided appropriate standards are met.

TXgard-Plus requires a dc supply of 10-30 V at up to 100 mA. Ensure the minimum dc supply of 12 V is observed at the detector, taking into account the voltage drop due to cable resistance.

For example, a nominal dc supply at the control panel of 24 V has a guaranteed minimum supply of 20V. The maximum voltage drop allowed is therefore 8V. TXgard-Plus can demand up to 100 mA and so the maximum loop resistance allowed is 80 Ohms. A 1.0 mm<sup>2</sup> cable will typically allow cable runs up to 2000m. Table 4 shows maximum cable distances given typical cable parameters.

**3.1 Location**

There are no rules which dictate the siting and location of detectors, however, considerable guidance is available from BS EN 50073:1999 and British Standard Code of Practice for the Selection, Use and Maintenance of Apparatus for the Detection and Measurement of Combustible Gases or Oxygen. In the USA refer to the National Electrical Code (NEC 1999). Similar international codes of practice may be used where applicable. In addition certain regulatory bodies publish specifications giving minimum gas detection requirements for specific applications.

**3.2 Mounting**

The mounting detail of TXgard-Plus is given in Diagram 1. TXgard-Plus should be installed at the designated location with the detector pointing down. This ensures that dust or water will not collect on the sinter and stop gas entering the detector.

**3.3 Cabling requirement**

Cabling to TXgard-Plus must be in accordance with the recognised standards of the appropriate authority in the country concerned and meet the electrical requirements of the detector. Crowcon recommend the use of steel wire armoured (SWA) cable and suitable explosion proof glands must be used. Alternative cabling techniques, such as steel conduit, may be acceptable provided appropriate standards are met.

TXgard-Plus requires a dc supply of 10-30 V at up to 100 mA. Ensure the minimum dc supply of 12 V is observed at the detector, taking into account the voltage drop due to cable resistance.

For example, a nominal dc supply at the control panel of 24 V has a guaranteed minimum supply of 20V. The maximum voltage drop allowed is therefore 8V. TXgard-Plus can demand up to 100 mA and so the maximum loop resistance allowed is 80 Ohms. A 1.0 mm<sup>2</sup> cable will typically allow cable runs up to 2000m. Table 4 shows maximum cable distances given typical cable parameters.

### 3. INSTALLATION (continued)

CSA	Resistance (Ohms per km)	Cable Loop	mm <sup>2</sup> (awg)	m (ft)	Max. distance
1.5 (15)	12.1	36.2	1.0 (17)	1000 (3280)	1500 (4920)
1.0 (17)	18.1	36.2	1.0 (17)	1000 (3280)	1500 (4920)

**Table 4: Maximum cable distances for typical cables**

All connections are made via the terminal board mounted in the base of the junction box (see Diagram 2). The 3 wires from the 96HD are colour coded and should be terminated in the corresponding colour coded terminal (terminals 4, 5 & 6). Terminals 1 (0 Vdc), 2 (12-30 Vdc) and 3 (4-20mA signal) are connected to the control equipment. TXgard Plus is factory set as a 4-20 mA sink device unless specified otherwise when ordering (see Section 2 to change configuration). Diagram 3 summarises the electrical connections.

**Note:** The junction box and cable armour must be earthed at the detector or control panel to limit the effect of radio frequency interference and to maintain electrical safety.

**Note:** The junction box for the Flangard-Plus is manufactured from marine-grade alloy, and has a powder-coated finish. Care should be taken during installation to protect the painted finish, as use in saline environments could result in paint flaking off from damaged junction boxes. This in no way compromises the performance of the detector, as the marine-grade alloy junction box is approved for use in offshore environments.

9

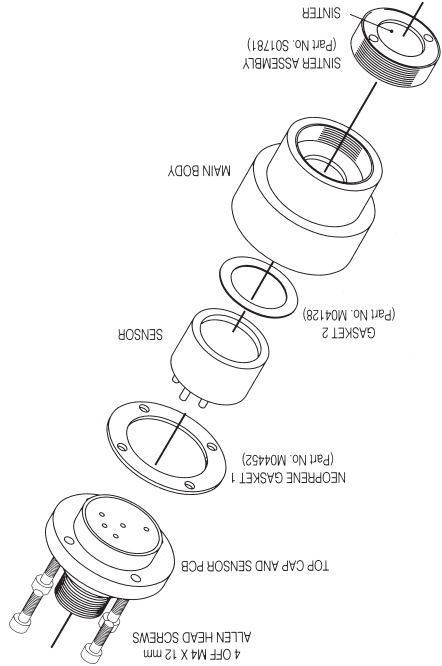
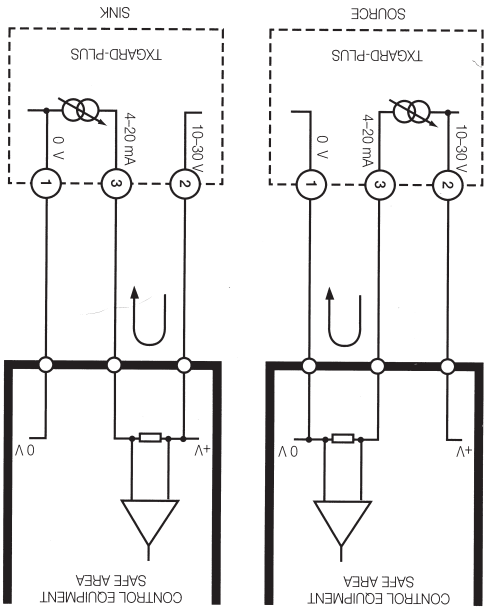

**Diagram 4: 96HD assembly**

All electrical connections to the optional relays are made via the 6-way terminal block on the terminal board in the base of the junction box (see Diagram 2). The relay contacts are rated 1 A @ 30 Vdc.

10

**Diagram 3: Electrical connections to TXgard-Plus**



**k** Re-assemble the 96HD housing taking time to ensure that the 3 mm

**l** Fit the 96HD sensor housing to the junction box ensuring that the Allen head screws are securely fixed into position.

**m** Replace amplifier ensuring the captive screws are fastened securely.

**n** Switch on power.

**o** Close the junction box rememembering to fasten the tamper proof grub screw into position.

**p** Follow the Commissioning Procedure given in 4.1.

**q** Re-calibrate as detailed in Table 3. To change either alarm level:

**a** Switch off and isolate power to the detector requiring attention.

**b** Open the junction box of the detector by loosening the tamper proof grub screw and removing the lid by rotating it anti-clockwise.

**c** Remove the amplifier from the terminal board.

**d** Ensure that the 'INHIBIT' link is set to 'N'.

**e** Re-fit the amplifier to the terminal board ensuring that all screws have been secured correctly.

**f** Apply power to the detector and allow the detector to stabilise.

**g** Place the end of 'CRO-Mag' over the 'MENU' pad. The decimal point above the word 'ZERO' will illuminate, the status LED will flash green and the display backlight will illuminate.

**h** With clean air present at the detector, place the end of the 'CRO-Mag' key over the 'UP' or 'DOWN' arrow pads to make the display read the desired alarm level.

### 4. OPERATION

#### WARNING

**Prior to carrying out any work ensure local regulations and site procedures are followed. Never attempt to open the detector or junction box when flammable gas is present. Ensure that the associated control panel is inhibited so as to prevent false alarms.**

**4.1 Commissioning Procedure**

**a** Open the junction box of the detector by loosening the tamper proof grub screw and removing the lid by rotating it anti-clockwise.

**b** Remove the amplifier and check that all electrical connections have been made and are correct as per Diagram 3.

**c** Replace the amplifier and close the junction box ensuring that all screws have been re-fitted correctly.

**d** Apply power to the detector. The status LED will show a steady green indicating normal operation.

**e** Leave the detector to stabilise for 1-2 hours.

**Zeroing the detector (ZERO Mode):**

**f** Place the end of 'CRO-Mag' over the 'MENU'. Green Status LED will flash. Decimal point above 'ZERO' will illuminate. Display backlight will illuminate. Decimal point above 'INHIBIT' may flash if the option has been internally selected.

**g** With no flammable gas present at the detector, place the end of the 'CRO-Mag' key over the 'UP' or 'DOWN' arrow pads to make the display read zero.

**Note:** Oxygen detectors may be zeroed in fresh air.

11

### 5. SPARE PARTS AND ACCESSORIES

**!** Using a long instrument screwdriver, turn the relevant ALARM SET pot mounted on the terminal board (see Diagrams 1 & 2) to adjust the alarm level. Tripping of the ALARM 1 level relay is confirmed by the status LED turning a steady red. Tripping of the ALARM 2 level relay is confirmed by the Status LED flashing red.

**j** Once the alarm level has been set, place end of 'CRO-Mag' over the 'UP' or 'DOWN' arrow pads and reset the display to read zero.

**k** Place the end of the 'CRO-Mag' over the 'MENU' pad to return the detector to normal operation, ie. No decimal points displayed, backlight off and the Status LED indicating steady green.

**l** Check that the detector operates correctly by applying test gas as necessary.

**m** Switch off and isolate power to the detector.

**n** Reset jumpers which may have been changed in step 'd' above.

**o** Replace the amplifier and close the junction box, ensuring that all screws have been re-fitted correctly.

**p** Apply power to the detector and allow to stabilise before checking correct operation.

**q** Re-calibrate if necessary as per section 4.1.

16

**Notes:**

**Zone 0:** An area classified, as Zone 0 will have ignitable concentrations of flammable gases, vapours or liquids present continuously or for long periods of time under normal operating conditions.

**Zone 1:** An area classified, as Zone 1 is likely to have ignitable concentrations of flammable gases, vapours or liquids present under normal operating conditions.

**Zone 2:** An area classified, as Zone 2 is not likely to have ignitable concentrations of flammable gases, vapours or liquids present under normal operating conditions.

**Calibrating the detector (CAL Mode):**

**h** Place the end of the 'CRO-Mag' over the 'MENU' pad. The decimal point above the word CAL will illuminate. Other indications remain unchanged.

**!** Apply calibration gas to the detector at a flow rate of 0.5 litres/min. (contact Crowcon for the supply of calibration gas.)

**j** Allow the gas reading to stabilise.

**k** Place the end of the 'CRO-Mag' over the 'UP' or 'DOWN' arrow pads to make the display read the correct concentration.

**l** If the control equipment display requires adjustment consult the operating manual for the equipment.

**Returning to normal operation (NORMAL Mode):**

**n** Place the end of 'CRO-Mag' over the 'MENU' pad. All decimal points will disappear and the backlight will turn off. The green status LED will be on steadily (assuming no gas is present at the detector).

**o** The detector is now operational.

**4.2 Routine maintenance**

The operational life of the sensors depends on the application, frequency and amount of gas being seen. Under normal conditions (6 months and re-calibrated as necessary following the steps given in 4.1, site practices will dictate the frequency with which detectors are tested. Crowcon recommend detectors are gas tested at least every 6 months and re-calibrated as necessary following the steps given in 4.1.

17

Description	Part number
Complete 96HD sensor housing with sensor only	Sensor
Hydrogen sulphide	(96HD/HS) S01750 E01229
Carbon monoxide	(96HD/CO) S01751 E01344
Oxygen	(96HD/OX) S01753 E01488
M20 to 1/2 inch NPT adaptor	M02125
M20 to 3/4 inch NPT adaptor	M02281
Gasket 1	M04452
Gasket 2	M04128
Sinter removal tool	M01614
Collector Cone	C01051
Weatherproof Cap	C01442
Replacement 'CRO-Mag'	C01697
Sinter assembly	S01781
Amplifier (Toxic version)	S01866
Amplifier (Oxygen version)	S01867
Terminal board	S01846
Relay board	S01847
Locrite No. 243	Contact Crowcon
Calibration gas	Contact Crowcon

18

Dimensions	200 x 115 x 115 mm (8" x 4 1/2" x 4 1/2")
Weight	2.2 kg (4.8 lbs)
Material	96HD sensor housing: 316 Stainless steel Junction box: Marine grade alloy
Temperature range	-10-55°C (14-131°F)
Humidity range	0-90% RH, non condensing
Ingress protection	IP66 with weatherproof cap
Explosion protection	Flameproof
Approval codes	II 2 G EX d IIC T6 (+55°C)
Safety Cert No.	Sra03ATEX1124
Standards	EN50014, EN50018, EN50270, UL2279
Zones	Certified for use in Zone 1 or Zone 2
Operating voltage	12-30 Vdc
Operating current	Relay version: 100 mA (maximum) Non-relay version: 50 mA (maximum)
Detector output	4-20 mA source or sink selectable
Relays outputs	2 x Alarm relays SPNO (SPNC option) 1 x Fault relay SPNC (SPNO option)
Contact rating	1 A @ 30 Vdc

### 5. SPECIFICATION

13

**f** Open the 96HD sensor housing by removing the four Allen head screws from the Top Cap with a 3mm Allen key.

**g** Remove the sensor from the Top Cap PCB.

**h** Fit the replacement sensor checking the part number is correct. This part number is labelled on the main body of the detector.

**!** Inspect the gaskets and replace if necessary.

**j** The sinter assembly will only need to be replaced if it has become blocked by dust or oil. Such blockage causes the response time of the detector to be slow and may affect sensitivity. To remove the sinter a removal tool (Part # M01614) is required. Locrite No 243 must be used on the sinter assembly threads to maintain certification.

**4.2 Routine maintenance**

**4.3 Sensor replacement/servicing of detectors**

**WARNING**

**This work should be carried out by Crowcon or an approved service centre unless suitable training has been received.**

TXgard-Plus uses the 96HD sensor housing which allows the user to replace the sensors, gaskets and sinter if necessary. An exploded view of the 96HD sensor housing is given in Diagram 4. The following procedure may be followed when servicing a TXgard-Plus detector:

**a** Switch off and isolate power to the detector requiring attention.

**b** Open the detector Junction box by loosening the tamper proof grub screw and removing the lid by rotating it anti-clockwise.

**c** Remove the amplifier.

**d** Disconnect the 3 sensor wires from the terminal board (terminals 4, 5 & 6).

**e** Unscrew the complete 96HD sensor housing from the junction box.

**Note:** If a spare 96HD sensor housing complete with new sensor is available ignore steps f to k and return the old 96HD to Crowcon or an approved service centre for repair.